

EN

FR

DE

ES

IT

BR

NL

PL

NO

DA

SV

FI

KO

MS

RU

# LCSU 4

## User Guide



**REF** Cat. No. 880051/880052  
Cat. No. 88005127/88005227



**REF** Cat. No. 880061/880062  
Cat. No. 88006127/88006227



<b>1 LCSU 4 Overview</b>	
– Important Information	4
– LCSU 4 - 800 ml (Cat. No. 880051/880052)	4
– LCSU 4 - 300 ml (Cat. No. 880061/880062)	4
<b>2 Description and Intended Use</b>	
– Intended Use	5
– Cautions and Warnings	5
– Limited Warranty	5
<b>3 LCSU 4 Setup</b>	
– Prepare the LCSU 4 for Operation	6
– Assemble 800 ml Version	6
– Operation with High Efficiency Filter Kit	6
– Assemble 300 ml Version	7
<b>4 User Instructions</b>	
– Check Before Each Use	8
– Power Source Options	8
– Control Panel and Indicator Symbols	8
– Suction Level Setting	8
– How to Operate and Adjust Suction level	9
<b>5 Battery Information</b>	
– Battery Charging	10
– Battery Test	10
– Charging Operations	10
– External Battery Charger	10
<b>6 Cleaning and Maintenance</b>	
– Cleaning	11
– Device Test	11
<b>7 Troubleshooting</b>	12
<b>8 Glossary of Symbols</b>	13
<b>9 Specifications</b>	14
<b>10 Regulatory Information</b>	16

# 1 LCSU 4 Overview

## Important Information

This User Guide covers two main versions of LCSU 4; one configured with 800 ml Canister, and one with 300 ml Canister. Both versions can be purchased with or without RTCA compliance. Unless otherwise specified, the information in these User Guides applies to all versions.

### Note

Inspect all parts when unpacking. If there are signs of damage or parts are missing - immediately notify the seller. Do not attempt to use the LCSU 4 if parts are damaged or missing.

## LCSU 4 - 800 ml (Cat. No. 880051/880052)

### Items Included:

- LCSU 4 Main Unit
- 800 ml Disposable Canister
- Patient Tube 1.8 m (6')
- Vacuum Tube
- AC/DC Adapter charger
- Battery
- User Guide
- Carry Bag (for 800 ml version)
- Wire Stand

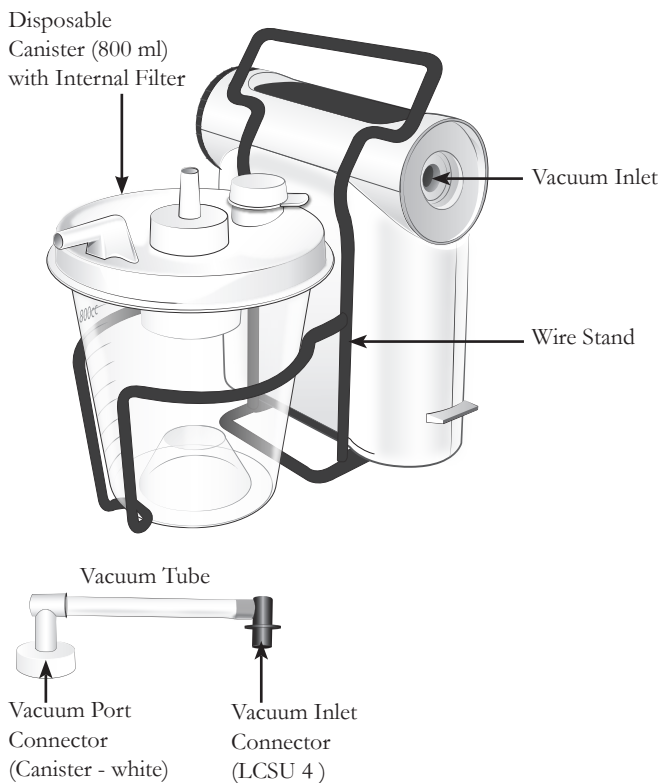

## LCSU 4 - 300 ml (Cat. No. 880061/880062)

### Items Included:

- LCSU 4 Main Unit
- 300 ml Disposable Canister
- Patient Port
- Patient Tube 0.9 m (3')
- AC/DC Adapter charger
- Battery
- User Guide
- Carry Bag (for 300 ml version)

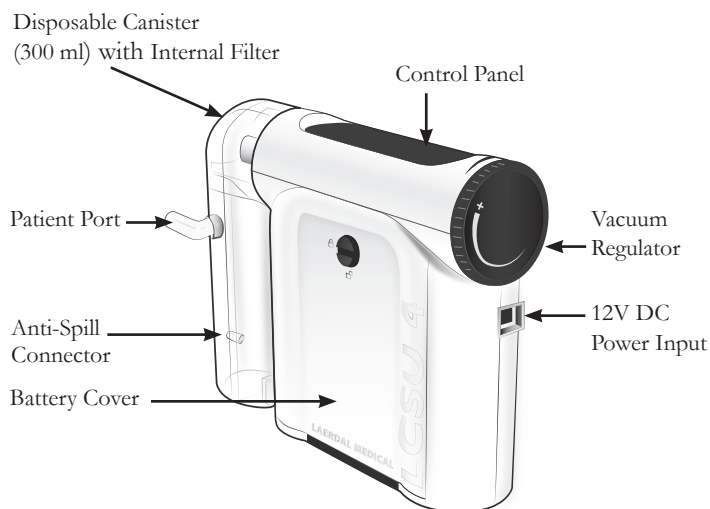

- The LCSU 4 Main Unit is the same for both versions. Each version can easily be converted to the other Canister option by ordering additional parts.
- For latest version of Spare Parts, Accessories and Consumables, visit [www.laerdal.com](http://www.laerdal.com)

## Intended Use

The LCSU 4 is a portable, electrically powered, medical suction device intended for field and transport use. It is intended for intermittent operation to remove secretions, blood or vomit from a patient's airway to allow ventilation. Higher vacuum levels are generally selected for oropharyngeal suction, and lower vacuum levels are usually selected for tracheal suctioning and the suctioning of children and infants.

### Notes

- Do not use this unit until you have carefully read and fully understood these User Guides. Contact Laerdal Medical or its authorized distributor for additional information if required.
- Use only Laerdal accessories supplied directly by Laerdal Medical or one of its authorized distributors to ensure that the LCSU 4 operates satisfactorily.
- When using the LCSU 4 at home, take care to keep out of reach of children and pets. Do not store the LCSU 4 next to a heater.

### Cautions and Warnings

#### Cautions

- Only use canisters, tubes and accessories that are approved for the device by Laerdal Medical.
- The LCSU 4 is not suitable for use in the presence of flammable liquids or gases; danger of explosion or fire.
- Do not use the LCSU 4 under environmental conditions that are outside ranges specified.
- Ingress of suctioned material into the pump can damage and/or disable the device. If suctioning of liquid from the Canister or patient into the pump is suspected, do not use the LCSU 4. Contact Laerdal Medical or your authorized distributor for advice.
- Changes or modifications not expressly approved by Laerdal Medical could void the user's authority to operate the equipment.
- Federal law (USA) restricts the LCSU 4 to sale by or on the order of a physician or other licensed medical authority.

#### Warnings

- Follow local protocols for back-up suction devices.
- Do not repeatedly block the patient tube for more than 10 seconds at a time at vacuum levels greater than 300 mmHg.
- The LCSU 4 should only be used by persons trained in the use of medical suction equipment, and according to local protocol.
- Unauthorized service attempts, opening or tampering with the LCSU 4 or its electrical components can damage or disable the device, and will void the Limited Warranty.
- Cat. No. 880052/880062 are approved according to RTCA/DO-160G Section 21 Category M but limited to battery operation use only. Use of the AC/DC Adapter charger (Cat. No. 886111) or DC Power cord (Cat. No. 884500) for charging or operation inside an aircraft must be avoided.
- Cat. No. 880051/880061 are not approved for use in aircrafts.
- Not intended for use in MRI environments.
- Disconnect the LCSU 4 from external power prior to cleaning.
- Consumables are single patient use only. Do not re-use. Re-use will lead to increased risk of cross-contamination, degradation of performance and/or device malfunction. Laerdal is not responsible for any consequences of re-use.

#### Limited Warranty

The LCSU 4 comes with a two (2) year limited warranty, excluding the Canisters, Tubing systems and Battery. Refer to the Laerdal Global Warranty for terms and conditions. For more information visit [www.laerdal.com](http://www.laerdal.com). The Battery is warranted for 90 days. Laerdal does not provide Service Parts for this product. Excluding the internal Battery, there are no user-serviceable/user-replaceable parts inside the LCSU 4 Main Unit.

## 3 LCSU 4 Setup

### Prepare the LCSU 4 for Operation

#### Note

All models are shipped with the Battery inside the unit, but not connected. Connect the Battery and charge it fully before using the unit. See Battery Charging (Chapter 5).

#### Assemble 800 ml Version

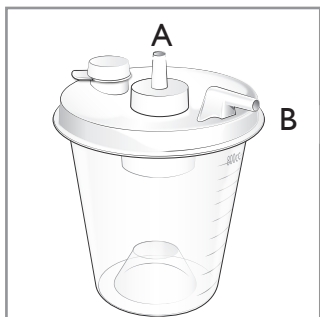

**Canister Ports**  
A - Vacuum Port  
B - Patient Port

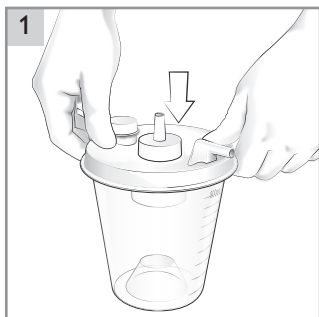

**1** Secure the Lid to the Canister.

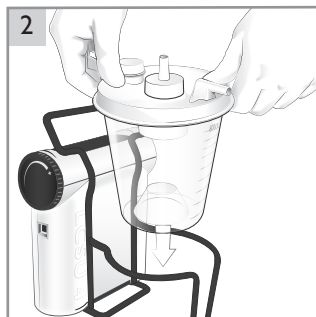

**2** Place the Canister into Wire Stand.

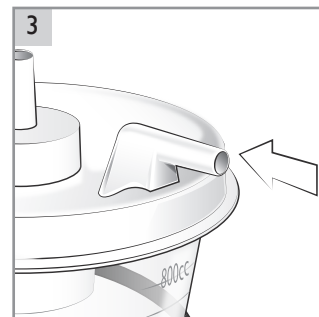

**3** Ensure that the Patient Port is accessible.

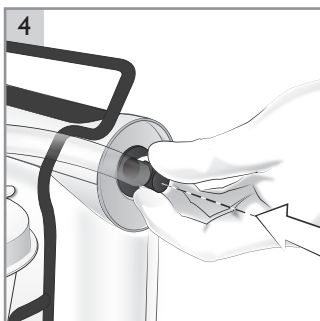

**4** Attach the Vacuum Inlet Connector to the Vacuum Inlet on the Suction Unit.

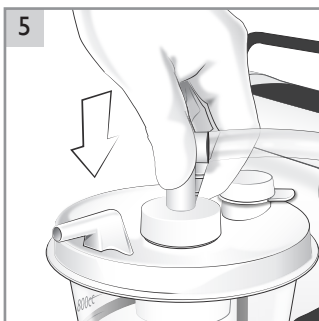

**5** Attach the WHITE Connector to the Vacuum Port Connector on the Canister.



**6** Check that all Vacuum Tube connections are firmly attached.

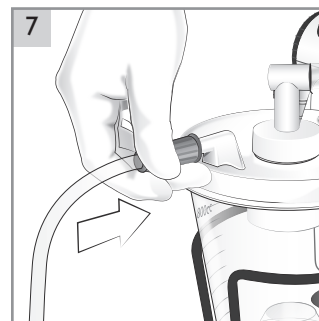

**7** Attach the Patient Tube to Patient Port on the Canister.

#### Note

The 800 ml Canister has an internal Filter in the Lid. The Canister is disposable and cannot be cleaned. The Filter automatically stops suction/flow when the Canister is full, or if the LCSU 4 tips over.

#### Caution

Always use the 800 ml Canister supplied by Laerdal, which has an internal Filter. Never connect any type of Patient Tubing directly to the LCSU 4 Vacuum Inlet Port Connection. Overflow of suctioned material into the LCSU 4 pump will result in loss of suction and permanent damage to the unit. In the event of overflow, do not use the LCSU 4. Contact Laerdal Medical or your authorized distributor.

#### Operation with High Efficiency Filter Kit

To increase filtration efficiency the Vacuum Tube may be replaced with a High Efficiency Filter Kit (Cat. No. 886116).

Ensure Filter IN points towards the WHITE connector, and OUT towards the BLUE. For Cleaning and Maintenance, see Chapter 6.

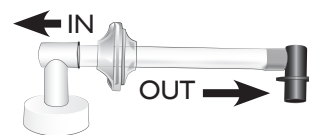

## Assemble 300 ml Version

- 1 Push the upper port connection into the Vacuum Inlet and check that the lower part of the Canister clicks in place.
- 2 Connect the Patient Port onto Patient Tube
- 3 Connect the Patient Port onto the Canister. Ensure that all connections are secure to prevent leakage.

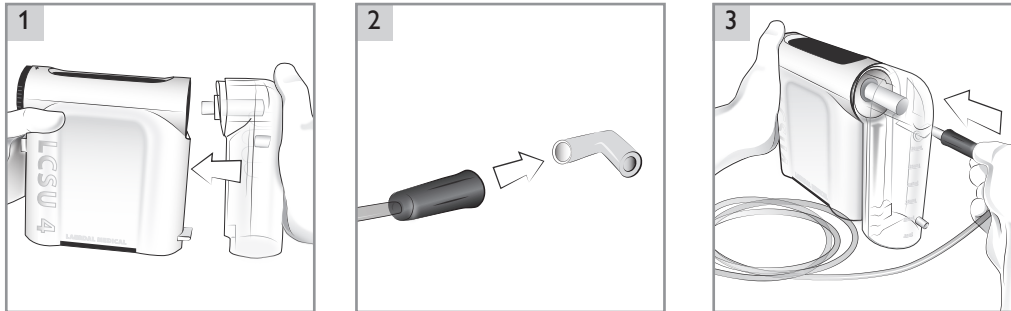

### Notes

- The 300 ml Canister is sealed, with an internal Filter. The Canister is disposable and cannot be cleaned. The Filter automatically stops suction/flow when the Canister is full, or the Filter becomes saturated if the unit tips onto its side during use.
- The 300 ml Canister (Cat. No. 886100) can also be used with the previous model LCSU 3. However, the LCSU 4 cannot be used with LCSU 3 Canisters.
- To improve the upright stability, a Wire Stand (Cat. No 886115) is offered as an Optional Accessory. This adds both a handle and a foot to the unit.

## 4 User Instructions

### Check Before Each Use

- 1 The suction unit should not be damaged.
- 2 The suction unit should be clean.
- 3 All parts should be properly assembled (Canister, Tubes etc.).
- 4 Check that a suction catheter is attached to the patient suction tube or suction adapter. Do not use the suction tube or suction adapter without a suction catheter attached.
- 5 Perform Device Test after each reassembly (see Chapter 6).
- 6 Check Battery level: While performing the Device Test the Battery level should not illuminate RED. If the Battery level illuminates RED, the Battery should be charged. See Charging Instructions (Chapter 5).

#### Note

Always have an extra Canister available in case the first Canister is filled completely, or the suction unit tips on to its side and the Filter becomes saturated and stops the suction/flow.

#### Warning

If the Canister fills and the shut-off mechanism activates, and you have no spare Canister ready for immediate replacement, shut off LCSU 4 and utilize alternative methods according to local protocol to clear patient's airway. Continued efforts to suction with a full canister may cause overflow that will prevent suctioning, damage the pump, void the unit warranty, and lead to prolonged downtime.

### Control Panel and Indicator Symbols

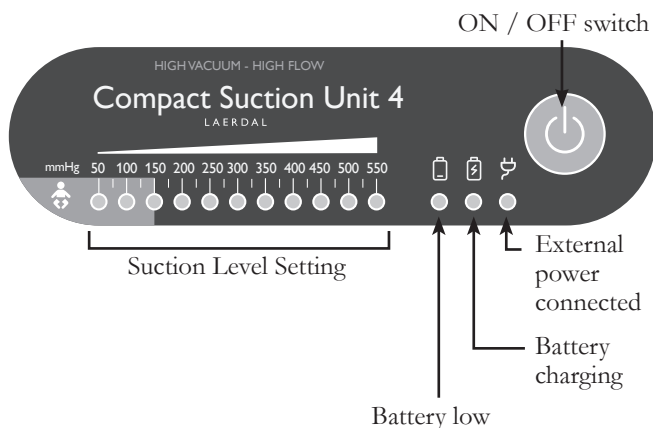

#### Suction Level Setting

- The Scale illuminates 'Green' to indicate the level of vacuum/suction strength
- The 'Light Blue' area indicates reduced suction levels for infants and small children

The LEDs have two brightness levels. Half illuminated indicates a halfway vacuum level, e.g., 175 is indicated by a fully illuminated 150 and a half illuminated 200 LED.

#### Warning

If the Low Battery symbol illuminates, immediately switch to an external power source to avoid interrupted operation. If the LCSU 4 does not receive external power, the Low Battery indicator will remain on and the unit performance will drop rapidly leading to complete LCSU 4 shutdown.

### Power Source Options

#### Internal Battery Operation

LCSU 4 is equipped with an internal Battery, NiMH 12 volt 1.6 Ah.

The LCSU 4 will run on battery power, unless connected to external power. Unplugging the external power source whilst running will stop the unit from operating. To restart, press the on/off switch.

#### External Power Source

LCSU 4 can be run from external power by use of the AC/DC Adapter Charger included. Plug the DC connector of the AC/DC Adapter Charger into the LCSU 4 12V DC Power Input Connection. Plug the AC plug to mains power socket. It is normal that the adapter becomes warm when in use.

### AC/DC Adapter Charger (Cat. No. 886111)



## How to Operate and Adjust Vacuum level

- 1 Unwind the Patient Tube (check that no kinks will obstruct flow).
- 2 Turn the unit “ON” by pressing the ON/OFF button.
- 3 Block the Patient Tube.

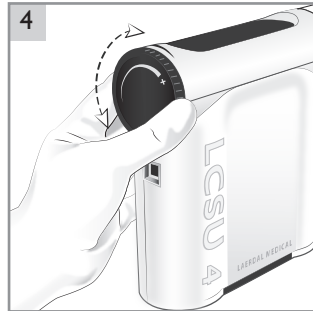
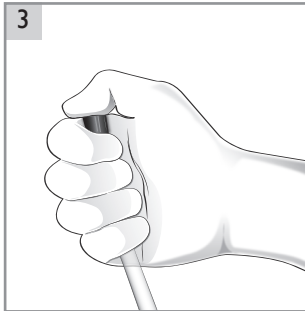

- 4 Set desired suction vacuum level by turning the Vacuum Regulator.
  - Turn clockwise (+) to increase vacuum
  - Turn counter-clockwise to decrease vacuum
- 5 The vacuum level will display on the Suction Level Setting Scale.
- 6 When the desired vacuum level is reached; unblock the patient tube immediately.

### **Warning**

Do not repeatedly block the patient tube for more than 10 seconds at a time at vacuum levels greater than 300 mmHg.

- 7 Apply necessary suction therapy. Apply appropriate suction catheter (not supplied by Laerdal).

### **Warning**

During patient treatment do not occlude or block the patient tube by intentional bending or squeezing. The patient tube should only be temporarily occluded by suctioning matter.

### **Note**

If LCSU 4 does not maintain the desired suction performance level, refer to Troubleshooting instructions (see Chapter 7).

## After Each Use

- 1 After suctioning, let LCSU 4 run for a moment to allow all suctioned material to flow from the Patient Tube into the Canister.
- 2 To avoid spills, connect Patient Tube to Anti-Spill Connector.

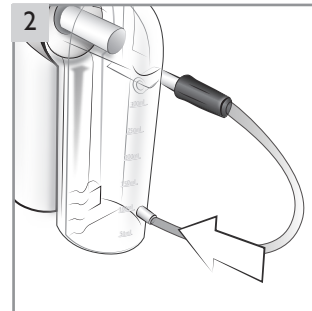

- 3 Disconnect and dispose of Canister and Patient Tube. Contact local authorities to determine the proper method of disposal of soiled canister and patient tube.
- 4 Clean the exterior and any reusable parts of the LCSU 4 assembly according to instructions (see Chapter 6).
- 5 Perform Device Test (see Chapter 6).
- 6 Place Battery on charge (see Chapter 5).

## 5 Battery Information

### Battery Charging

#### Note

Use only Laerdal Battery Cat. No. 886113.

#### Cautions









- Use of other than Laerdal brand Battery may result in errors related to the Battery status indicator, reduction of the Battery operation time, failure to effectively operate LCSU 4, and/or give rise to hazards to operator and/or patient.
- Do not operate the unit for more than a few minutes if the RED Low Battery indicator is illuminated. Recharge the Battery as soon as possible.

#### When in operational use

- An empty Battery must charge up to 5 hours to reach full capacity. Battery charging time may be increased when charging below 10 °C
- Battery run time: Approximately 45 minutes of continuous operation at zero vacuum level (free flow), fully recharged.
- Always fully charge Battery.

To prolong Battery lifetime it is recommended to place the Battery on continuous charge. It will not harm the unit. If continuous charging is not possible, charge Battery for minimum 5 hours once a month.

Follow the LED status on the Control Panel on the LCSU 4 and charge the Battery as necessary.

Icon	LED Indicator	Status
		Battery level low
		Charging
		Charging is pending or battery not installed
		Battery is fully charged
		External power connected

### Battery Test

Test Battery every 6-12 months.

- 1 Start the test with a fully charged Battery.
  - 2 Set maximum vacuum level.
  - 3 Let the unit run for 20 minutes (free flow).
  - 4 Block Patient Tube.
  - 5 Unblock the tube immediately after reaching 550+ mmHg
- If vacuum level fails to reach 550+ mmHg the Battery should be replaced.



#### Warning

Do not block the patient tube for more than 10 seconds at a time at vacuum levels greater than 300 mmHg.



#### Caution

Replace the battery when it does not pass battery test.

### Optional Power/Charging Accessories External Battery Charger (Cat. No. 886112)

The Battery can be charged externally by removing it from the LCSU 4 unit and using the External Battery Charger.

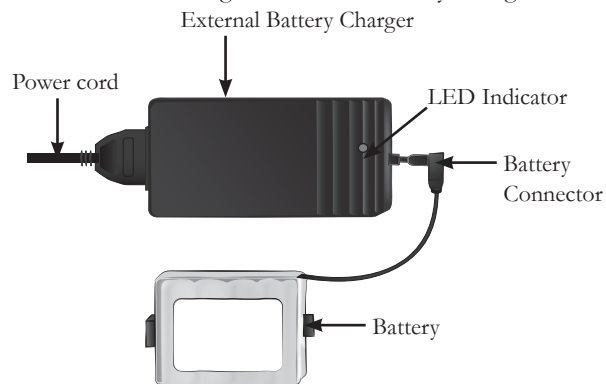

An empty Battery must charge up to 5 hours to reach full capacity. Follow the LED Indicator and charge the Battery as necessary.

LED Indicator	Status
LED not illuminated	Plugs not connected
Yellow LED flashes	Charging is pending
Yellow LED illuminated	Charging
Green LED illuminated	Battery is fully charged (*)
Red LED flashes	Charge failure

\* The Battery can be left on continuous charge, even if the Green LED is illuminated. It will not harm the units.



#### Caution

Do not cover the Charger. When in use, it is normal that the Charger and the Battery becomes warm.

### DC Power-Cord (Cat. No. 884500)

DC Power-cord for connection to vehicle 12V DC is required. Plug the smaller power connector into the LCSU 4 12V DC Power Input Connection. Plug the larger connector into the vehicle 12V DC power receptacle.

## Cleaning



### Cautions

- Disconnect the LCSU 4 from external power prior to cleaning. Use a minimum amount of liquid to prevent any electrical shock hazard.
- Do not immerse the LCSU 4 or allow it to stand in water or other liquids. This might damage the device, and cause electrical hazard.



### Warning

Do not pump any cleaning solution or other liquids through the vacuum pump, i.e. through the Vacuum Connector. This can damage the LCSU 4.

### Main Cabinet

- 1 Disconnect from external power supply.
- 2 Clean Cabinet surfaces by carefully wiping with a soft cloth or sponge with mild detergent. Use hand dishwashing liquid or similar that is compatible with the Material Chart (see Chapter 9).
- 3 Dry all surfaces using a clean cloth or paper towel.

### Canisters and Patient Tubes

Dispose after use.



### Note

The Canisters and Patient Tubes are all disposable items. Do not attempt to clean or reuse these. Due to the risk of cross contamination, all disposable items must be replaced after each use. They are for single-patient use only. Contact local authorities to determine the proper method of disposal of soiled canister and patient tube.

### Vacuum Tube (for 800 ml version) and Wire Stand

Wash by immersing and scrubbing in hand dishwashing liquid or similar.

- 1 Rinse thoroughly in pure water.
- 2 Allow to dry. Disinfect if desired.

### High Efficiency Filter Kit (for 800 ml Version)

- Filter cannot be cleaned or disinfected.
- Replace Filter immediately if contamination or discoloration is observed, or if it gets wet.

\* If the unit is used on patients in areas where cross contamination is an issue, it is recommended that the Filter is replaced after each use.

### Carry Bag

Wipe the bag according to instructions provided above for Main Cabinet. Do not launder.

### Device Test

After each reassembly, and before returning a LCSU 4 to operational use, the Device Test should be performed:

- 1 Disconnect from external power
- 2 Start the test with a fully charged Battery
- 3 Turn the unit "ON"
- 4 Turn the vacuum level regulator to maximum
- 5 Block the Patient Tube
- 6 When the vacuum reaches minimum 500 mmHg immediately release the blocking. The device is fully functioning if it passes this test.



### Warning

Do not block the patient tube for more than 10 seconds at vacuum levels greater than 300 mmHg.



### Caution

Do not attempt to use any LCSU 4 that has not passed the above test. If the LCSU 4 unit does not test satisfactorily, recheck all parts of the assembly and test once again. If necessary, contact Laerdal Medical or one of its authorized distributor.

### Disposal

When discarding the LCSU 4, we recommend it be discarded according to local protocol.

This appliance is marked according to the European directive 2012/19/EU on Waste Electrical and Electronic Equipment (WEEE). By ensuring this product is disposed of correctly, you will help prevent potential negative consequences for the environment and human health, which could otherwise be caused by inappropriate waste handling of this product.



The symbol on the product, or on the documents accompanying the product, indicates that this appliance may not be treated as household waste. Instead it shall be handed over to the applicable collection point for the recycling of electrical and electronic equipment. Disposal must be carried out in accordance with local environment regulations for waste disposal.

For more detailed information about treatment, recovery and recycling of this product, please contact your local city office, your household waste disposal service or the Laerdal representative where you purchased the product.

## 7 Troubleshooting



### Warning

Potential for Electrical shock. Do not attempt to open or disassemble pump or electrical accessories.



### Caution























The LCSU 4 may not achieve the highest vacuum levels when operated at high altitudes.



### Note

If the LCSU 4 condition is not resolved, contact Laerdal Medical or one of its authorized distributors for advice.

Fault	Condition	Action
LCSU 4 cannot be operated from battery	Battery uncharged or not connected	Verify that the Battery is properly installed and charged.
The LCSU 4 operates, but little or no suction available.	Canister or tube not properly connected	Verify proper Canister and Tubing connections. Check system for possible leaks in Canister and/or Tubing connections.
	Canister full	Remove and replace Canister
	Poor vacuum connection between LCSU 4 and Canister	Follow procedure for proper assembly of Canister and Tubing
	Lid (800 ml canister only) not properly sealed	Check that the lid is properly secured to the Canister
	Patient tube twisted or blocked	Check that the Patient tube is not blocked or twisted, or alternately replace the tube
	Filter clogged	Check that the Filter has not been clogged (300 ml canister only).
Vacuum level is too high or too low	Incorrect vacuum level set	Follow procedure for adjusting vacuum suction level
Battery will not charge	Battery or AC/DC adapter charger not connected or aged battery	Verify that the Battery is connected. Re-connect external power and observe charging. Replace battery
Insufficient power level	Battery not fully charged or aged battery	Charge the Battery for 5 hours. Perform the Battery Test. Replace battery

Symbols	Definition	Symbols	Definition
	This product is in compliance with the essential requirements of Council Directive 93/42/EEC Medical Device Directive, as amended by Council Directive 2007/47/EC, class IIa The product is in compliance with Council Directive 2011/65/EU on restriction of the use of certain hazardous substances (RoHS 2).		Single Patient Use. Do not re-use.
	Medical Device		Transport storage temperature range
	Device ingress protection is rated IP33		Humidity
	Unique Device Identification (UDI) for medical equipment		Atmospheric pressure
	Unique product type identification		Consult User Guide
	Serial number		Caution: Federal law restricts this device to sale by or on the order of a physician.
	The products is eligible to bear the CSA Mark with adjacent indicators 'C' and 'US' for Canada and US Exemptions: External Battery Charger (Cat. No. 886112) and DC Power-Cord (Cat. No. 884500)		Date of production
	Center positive polarity indicator		Warning / Caution
	Direct current		Note
	Disposal must be carried out in accordance with local environment regulations for waste disposal.		Type BF applied part, according to IEC 60601-1 Applied part of the LCSU4 is the catheter (not supplied by Laerdal) which is connected to the catheter adaptor.
	Battery recycling, Nickel-Metal Hydride battery		Not made with natural rubber latex

## 9 Specifications

Power Source Options			
Battery	Rechargeable, NiMH 12 volt 1.6 Ah		
Power-cord	DC (12 V) Dry Location Use Only		
AC/DC Adapter Charger (Dry Location Use Only)	Input: 100-240 V, 50-60 hz, 1.2 A	Output: +12 V, 3.4 A	
External Battery Charger (Dry Location Use Only)	Input: 110-240 V, 50-60 hz, 250 mA	Output: +18.5 V, 0.6 A	
Environmental Conditions			
Operating and Storage Temperature	0 °C (32 °F) to + 40 °C (104 °F)		
Operating and Storage Relative Humidity	0 to 95% (non condensing)		
Operating Atmospheric Pressure	9 psi (62 kPa) – 15.4 psi (106 kPa)		
Charging temperature	10 °C (50 °F) to + 40 °C (104 °F)		
Short-term Storage & Transport Temperature	-40 °C (-40 °F) to + 70 °C (158 °F)		
Humidity (Operating & Storage)	0 to 95% (non-condensing)		
Storage & Transport Atmospheric Pressure:	7.3 psi (50 kPa) – 15.4 psi (106 kPa)		
The time required for the LCSU4 to warm from the minimum storage temperature between uses until it is ready for intended use is minimum 50 minutes at room temperature.			
The time required for the LCSU4 to cool from the maximum storage temperature between uses until it is ready for intended use is minimum 60 minutes at room temperature.			
Physical Characteristics			
Dimensions	880051/880052 (LCSU 4, 800 ml)	23.6 cm x 19 cm x 23.6 cm (9.3" x 7.5" x 9.3")	
	880061/880062 (LCSU 4, 300 ml)	18.5 cm x 26.2 cm x 8.1 cm (7.3" x 10.3" x 3.2")	
Weight	880051/880052 (LCSU 4, 800 ml):	2 kg (4.4 lbs)	
	880061/880062 (LCSU 4, 300 ml):	1.6 kg (3.5 lbs)	
Canister Capacity	300 ml	800 ml	
Performance			
Expected service life	3 years This is assuming 5 suction passes per day lasting 15 seconds. The service life may be longer if less frequent use.		
Air flow at Vacuum Inlet (without canister attached)	All configurations	30 LPM (free flow) typical (May be less when running from internal battery)	
	Vacuum - Max.	550+ mmHg	
	Vacuum - Range	550+ mmHg	
	Vacuum Indicator accuracy	± 5% of full scale	
High Efficiency Filter Kit	With the High Efficiency Filter Kit installed the unit is in accordance with ISO 10079-1. The Kit reduces the Air flow and Battery run time. The filter has viral and bacterial filtration efficiency of at least 99.9% with a mean particle size (MPS) of $3.0 \pm 0.3 \mu\text{m}$ .		
Material Chart			
Cabinet front	PC		
Battery Cover	PC		
Vacuum Regulator	PC		
Bottom Cover	PC		
Vacuum Inlet Cover	PC		
Control Panel	PVC		
800 ml Disposable Canister	GPPS	Lid: HDPE	Internal Filter: Aerostate
Vacuum Tube	Silicone, K-Resin		
Vacuum Port Connector	TPR		
Vacuum Inlet Connector	PC		
High Efficiency Filter	PP		

Filter housing	K-Resin	
300 ml Disposable Canister	PC	Internal Filter: PE
Patient Port	PP	
Patient Tube	PVC	
Wire Stands	Steel, PVC	
Electromagnetic Emissions Tests		
Emissions Test	Standard or test	Compliance
Conducted and radiated RF emissions	CISPR 11	Group 1 Class B
Harmonic distortion	IEC 61000-3-2	Complies
Voltage fluctuations/ flicker emissions	IEC 61000-3-3	Complies
Electromagnetic Immunity Tests		
Immunity Test	Standard or test	Compliance Level
Electrostatic discharge	IEC 61000-4-2	± 8 kV contact ± 2 kV, ± 4 kV, ± 8 kV, ± 15 kV air
Radiated RF EM fields	IEC 61000-4-3	10 V/m 80 MHz- 2.7 GHz 80% AM at 1 kHz
Proximity fields from RF Wireless communications equipment	IEC 61000-4-3	380-390 MHz: 27V/m 430-470 MHz: 28V/m 704-787 MHz: 9V/m 800-960 MHz: 28V/m 1700-1990 MHz: 28V/m 2400-2470 MHz: 28V/m 5100-5800 MHz: 9V/m
Electrical fast transients / bursts*	IEC 61000-4-4	± 2 kV
Surges Line-to-line*	IEC 61000-4-5	± 0,5 kV, ± 1 kV
Conducted disturbances induced by RF fields*	IEC 61000-4-6	3 V 0,15 MHz – 80 MHz 6 V in ISM and amateur radio bands between 0,15 MHz and 80 MHz
Voltage dips*	IEC 61000-4-11	0% UT; 0,5 cycle At 0°, 45°, 90°, 135°, 180°, 225°, 270 ° and 315° 0% UT; 1 cycle and 70% UT; 25/30 cycles Single phase: at 0°
Voltage interruptions*	IEC 61000-4-11	0% UT; 250/300 cycle
Rated power frequency magnetic fields	IEC 61000-4-8	30 A/m 50 Hz or 60 Hz
Electrical transient conduction along supply lines, DC power port	ISO 7637-2	Test pulse severity level: III in Table A2 of ISO 7637-2

\*AC/DC adapter only.

## 10 Regulatory Information

---

### International Travel

This suction unit is equipped with an AC/DC Adapter Charger allowing operation on any AC voltage (100-240 VAC, 50/60Hz).

### Regulatory Information

#### Classification

- Electrically powered medical suction equipment for field and transport use, according to ISO10079-1.
- High flow/High vacuum, 50 – 550+ mmHg
- Not suitable for the use in the presence of flammable liquids or gases.
- Internally powered/class I equipment type BF, according to IEC 60601-1
- Protection class IP33 and standard power supply
  - Protected against solid foreign objects of 2.5 mm Ø and greater.
  - Protected against spraying water.
- Intermittent Operation: 30 minutes on, 30 minutes off

#### Certifications

Cat. No. 880052/880062: Meets RTCA/DO-160G - Section 21 Category M (for battery operation only; commercial aircraft, airborne equipment).

#### Electromagnetic Conformity

LCSU 4 is intended for use in the following environments: Professional Healthcare Facility environment, Home Healthcare environment and Emergency Medical Services environment.

Essential performance of the LCSU 4 is identified as connection of the patient hose to the exhaust outlet. This is prevented by coding of the outlet. EMC disturbances cannot affect this behavior.

No particular actions are required to maintain safety and performance with regard to electromagnetic disturbances for the expected service life.



#### Warnings

- Use of this equipment adjacent to or stacked with other equipment should be avoided because it could result in improper operation. If such use is necessary, this equipment and the other equipment should be observed to verify that they are operating normally.
- Use of accessories, transducers and cables other than those specified or provided by the manufacturer of this equipment could result in increased electromagnetic emissions or decreased electromagnetic immunity of this equipment and result in improper operation.
- Portable RF communications equipment (including peripherals such as antenna cables and external antennas) should be used no closer than 30 cm (12 inches) to any part of the LCSU 4, including cables specified by the Laerdal Medical. Otherwise, degradation of the performance of this equipment could result.

Laerdal, the Laerdal logo, Laerdal Compact Suction Unit, and LCSU are trademarks of Laerdal Medical AS or its affiliates.  
© 2025, Laerdal Medical AS. Ownership and all rights reserved.

Date of issue: 2025-08



Laerdal Medical AS  
P.O. Box 377  
Tanke Svilandsgate 30, 4002 Stavanger, Norway  
T: (+47) 51 51 17 00



20-05448 Rev U

---

[www.laerdal.com](http://www.laerdal.com)



**Laerdal**  
helping save lives